

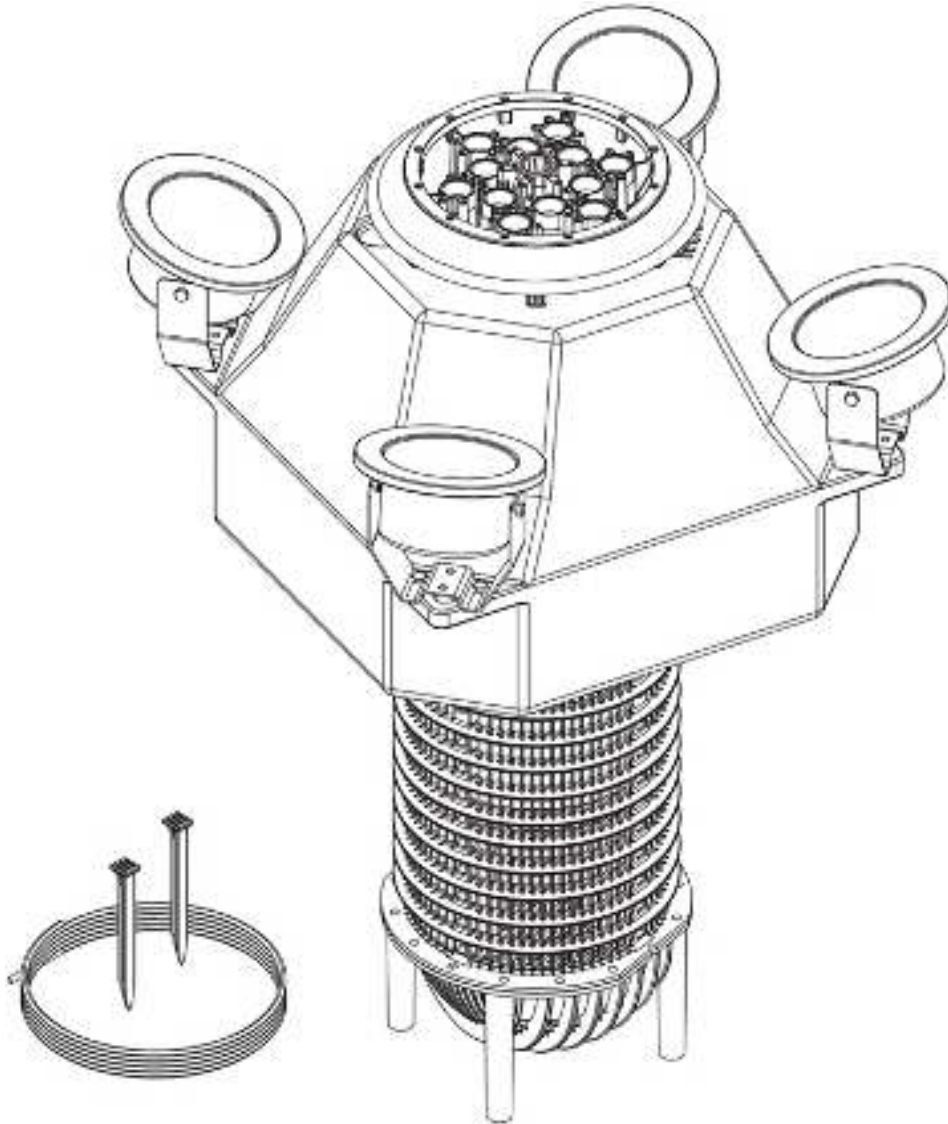

# 2HP FUSION Series Owner's Manual



## **Aquatic Technologies**

41 Yazaki Way, Carrum Downs VIC 3201  
Ph: (03) 9071 2442 [aquatictechnologies.com.au](http://aquatictechnologies.com.au)

## Parts Included

- Aerating Fountain (1)
- Standard Nozzle Package (1)
- Motor Cord with Quick Disconnect (1)
- Mooring Rope (30m)
- Mooring Stakes (2)

## Optional Accessories

- LED Lighting
- Extended Nozzle Package
- Twister Nozzle Package

## Safety Instructions

**IMPORTANT: Reading and understanding the instructions and warranty disclaimer are necessary prior to product installation and operation.**

- Under NO circumstances should anyone enter the water with the electrical equipment plugged in.
- NEVER run the unit out of the water. It may damage the motor seals.
- NEVER lift or drag the fountain by the power or light cord.
- Suitable for FRESHWATER applications only.
- The fountain suction screen should be inspected for clogging on a monthly basis. If matted weeds, leaves, or plastic bags are present, remove them with a bristle brush. Failure to keep the suction screen clear of blockages will cause low water flow and may cause premature motor failure. This type of failure is NOT covered under the Manufacturer's Warranty.
- In freezing conditions, the fountain must be removed from the water body and stored in an area above 0°C.
- The manufacturer, importers or its distributors are not liable for electrician's fees incurred for troubleshooting electrical issues.

## ~ Table of Contents ~

Steps to Prep Fusion for Water.....	3	Appendix A .....	8
• Nozzle Build		Standard Nozzle Package	
• Individual Nozzle Instructions in Appendix A		1. Cluster Arch .....	A1
• Mooring & Light Installation		2. Daffodil .....	A2
Fusion Pump Parts List.....	5	3. Flare.....	A3
Fusion Vertical Parts List.....	6	4. Lily.....	A4
Troubleshooting Guide .....	7	5. Super Lily.....	A5
		6. Tornado.....	A6

## NOZZLE BUILD TIPS AND WARNINGS

- All nozzle builds are in Appendix A
- When building the Nozzle, it is best to work from inside out to provide room to work.
- Center Nozzle will always be installed last.

### **Important Notice on the FUSION Series Multi-Nozzle Components Carry No Warranty When Assembled Improperly**

This Innovative Multi-Nozzle Casting was designed to offer you the flexibility to switch spray patterns as desired. The screws provided can be inserted multiple times in various locations without damaging the holes. Extra parts have been included as spares in the event they are needed.

Nozzles should be assembled using even and gradual tightening. The screws should be tightened snugly using hand tools only and opposing sides should be tightened evenly. **Over-torquing the screws may result in damages not covered under the manufacturer's warranty. Power tools are not allowed.**

The assembled nozzle should be handled by the base. Transporting the assembly using the individual tube assemblies or components may result in damages not covered under warranty. Nozzle components are warranted for 30 days and solely replaced due to manufacturing defects. All other damages caused by improper handling and/or assembly will require replacement parts purchased through your distributor.

There is a separate instruction sheet to use when installing the Optional Twister Module. If you experience difficulty implementing the build for your preferred spray pattern based upon the instructions provided, please contact Aquatic Technologies for assistance.

**Unlike the pump itself, the Twister Module carries a one (1) year manufacturer's warranty against defects.**



## Mooring Rope and Optional Light Set Installation

### Step #1

Fasten mooring rope to the large holes on two opposing sides of the float. Make sure to place the knot on the bottom side of the float as to not interfere with the light bracket.

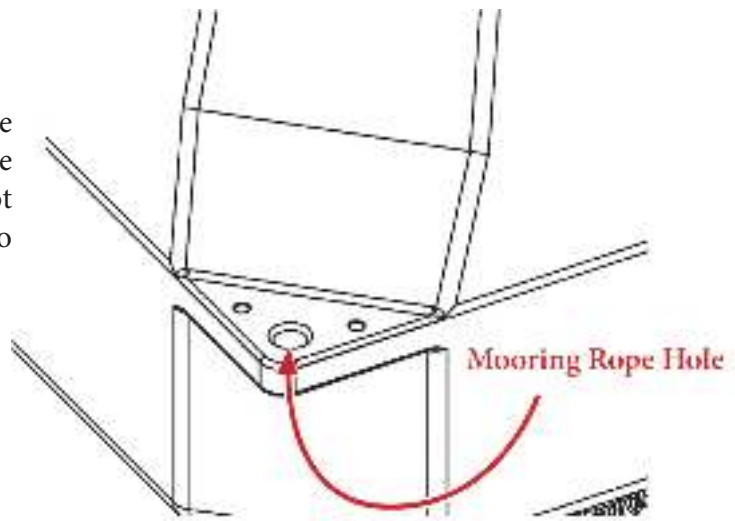

### Step #2

Mount the optional light bracket to the float making sure that the power cable is away from the float. Place bracket in the corner using the provided hardware in the two outer holes as shown. Bracket will contour over the mooring rope.

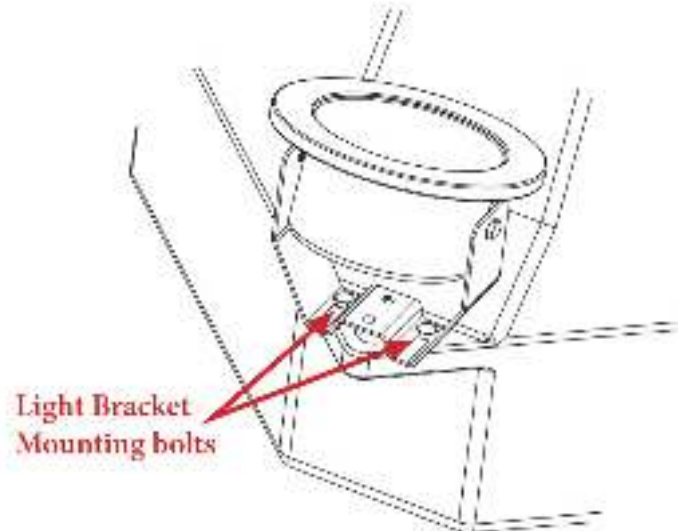

### Step #3

For the 2hp unit, plug the light set cord into the power outlet.

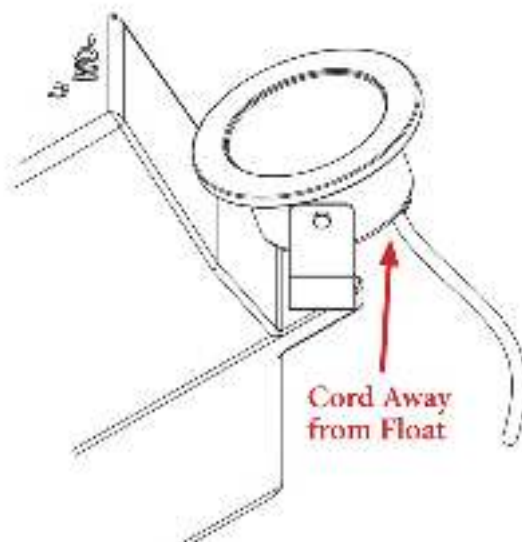

## 1-Stage or 2-Stage Fusion Pump Parts List

ITEM NO.	PART NUMBER	DESCRIPTION	QTY.
1		BOLT	
1-STAGE	80BH-0.25X3.50	1/4-20x3.5" HEX HEAD 14	3
2-STAGE	80BH-0.25X6.00	1/4-20x6" HEX HEAD 16	3
	80WL-0.25	1/4" LOCK WASHER 75	3
	80WF-0.25-N	1/4" NARROW WASHER - 1/2" OD 64	3
2	41-OF	OUTFLOW	1
3	40-IFS-2	INTERMEDIATE FLOW STRAIGHTENER 18-35 *One Per Stage (Stage = Prop + IFS)	*
4	80BR-0.31X0.75	5/16-18x0.75" PHIL RH SCREW 87	1
	80WF-0.31	5/16" FLAT WASHER 67	1
	80WL-0.31	5/16" LOCK WASHER 76	1
5	80WB-0.31	5/16" BELLVILLE WASHER	1
6		PROP	
(0.5hp)	40-P-07.0	PROP - 07 DEGREE - 3 BLADE	1
(1.0hp)	40-P-06.0-W	PROP - 06 DEGREE - 3 BLADE #129	2
(1.5hp)	40-P-08.0	PROP - 08 DEGREE - 3 BLADE	2
(2.0hp)	40-P-10.0-3S	PROP - 10 DEGREE - 3 BLADE S#115	2
7	40-SH-2	SECONDARY SHROUD (ONLY FOR 2-STAGE)	1
8	40-P-00	PROP SPACER (ONLY FOR 2-STAGE)	1
9	40-SH-1	PRIMARY SHROUD	1
10	80S-0.005	.625"x.005" SHIM 59 Qty <i>Varies by unit</i>	
11	41-SW	EXTENDED SHAFT WASHER	1
12	80BS-06X1.0	#6-18x1" SELF TAP SCREW	2
13	40-F-1	S2 INLET FAIRING	1
14	40-PH	PUMP HOUSING	1
15	80BT-0.25X0.63	1/4-20x0.625" TRUSS HEAD 30	3
	80WL-0.25	1/4" LOCK WASHER 75	3
	80WF-0.25	1/4" FLAT WASHER 64	3
16	80BSC-0.31X0.63	5/16-18x0.625" BUTTONHEAD SC 43	3
	80WF-0.31	5/16" FLAT WASHER 67	3
	80WL-0.31	5/16" LOCK WASHER 76	3
17	41-SRR	SHAFT RETAINING RING	1
18	41-RSK	0.188"x0.250"x0.75" LONG RECTANGULAR KEY	1
19	52MA2-0.511-L2	0.5HP 50HZ 1PH 230V MOTOR ASSEMBLY	1
	52MA2-1.011-L2	1.0HP 50HZ 1PH 230V MOTOR ASSEMBLY	1
	52MA2-1.511-L2	1.5HP 50HZ 1PH 230V MOTOR ASSEMBLY	1
	52MA2-2.021-L2	2.0HP 50HZ 1PH 230V MOTOR ASSEMBLY	1
	EV-H-ZIPTIE	ZIP TIE	2

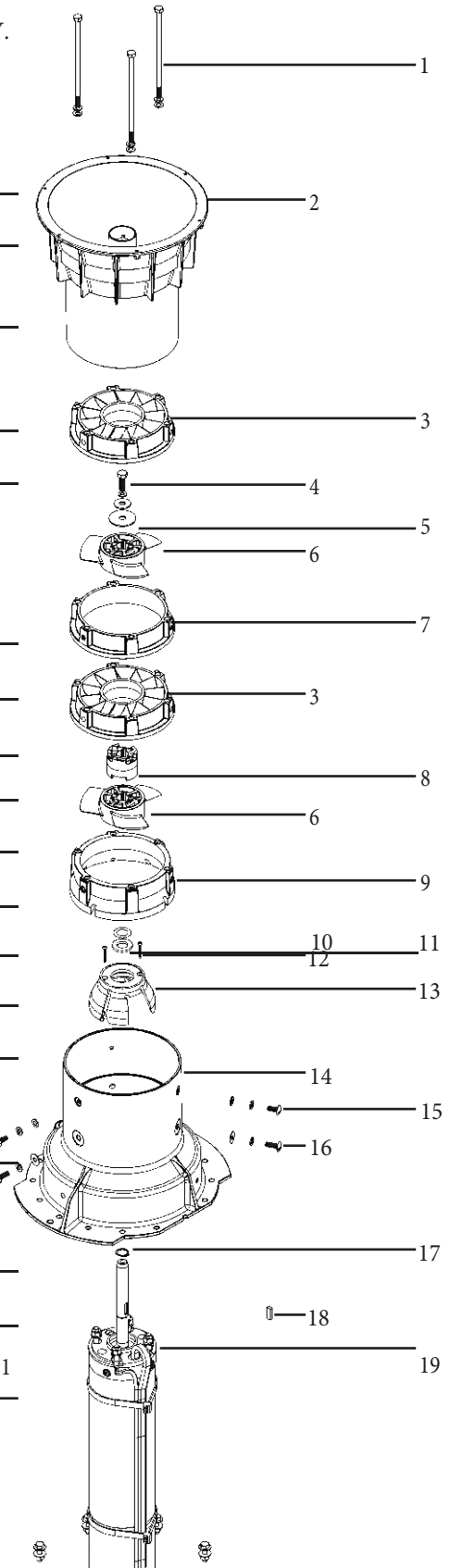

## Vertical Parts List

ITEM NO.	PART NUMBER	DESCRIPTION	QTY.
1	41-FLARE	FLARE	1
2	41-BASE	MULTI NOZZLE BASE	1
3	41-OF	OUTFLOW	1
4	FLOAT	FUSION FLOAT	1
0.5HP -1.0HP	41-FLOAT-S	FUSION FLOAT - SMALL	1
1.5HP -2.0HP	41-FLOAT-L	FUSION FLOAT - LARGE	1
5		PUMP ASSEMBLY - SEE PAGE 6	1
6	MOTOR ASSEMBLY		
0.5HP	52MA2-0.511-L2	0.5, 230, 1 2W MTR ASSY	1
1.0HP	52MA2-1.011-L2	1.0, 230, 1 2W MTR ASSY	1
1.5HP	52MA2-1.511-L2	1.5, 230, 1 2W MTR ASSY	1
2.0HP	52MA2-2.011-L2	2.0, 230, 1 MTR ASSY	1
7	40-SCR	MOLDED SUCTION SCREEN	1
8	40-SCR-EC	MOLDED SUCTION SCREEN END CAP	1

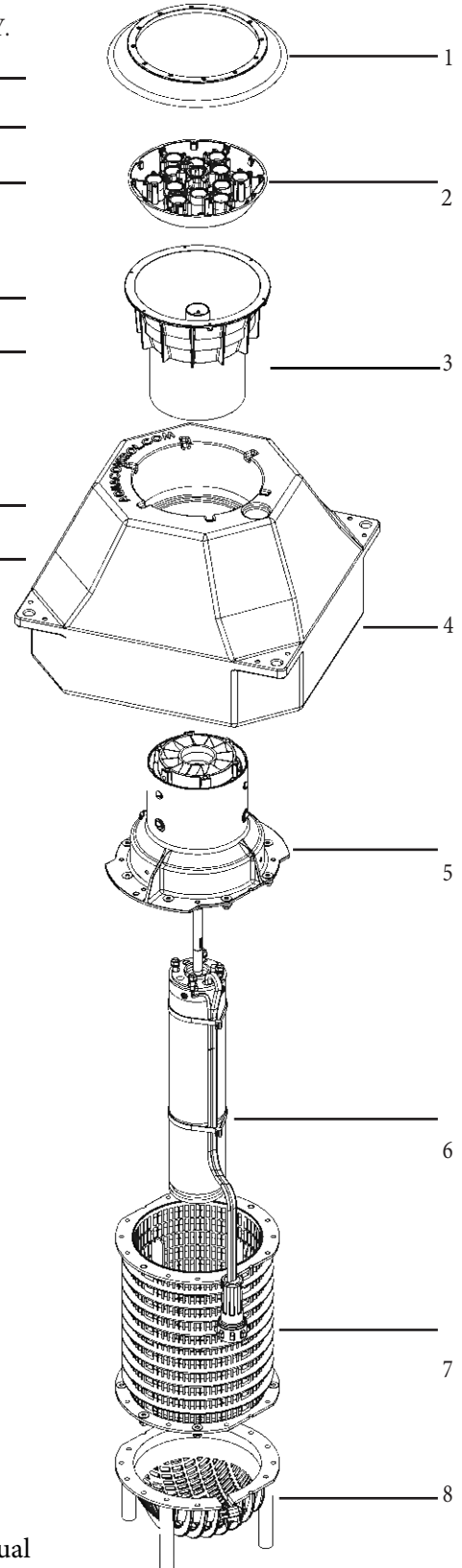

## Fusion Series Troubleshooting Guide

TROUBLE	CHECK	POSSIBLE SOLUTIONS
Fusion does not operate  -OR-  Starts then stops	Not plugged in	Cord must be plugged into a 3-wire outlet that is protected by a GFCI (Ground Fault Circuit Interrupter).
	GFCI/RCD Tripped	Reset GFCI/RCD. If GFCI/RCD will not reset or trips immediately, unplug the pump & lights and reset GFCI/RCD. If GFCI/RCD will still not reset, there may be a problem with the incoming power. If the GFCI/RCD resets, plug the pump. If the GFCI/RCD trips, there may be a problem with the pump cord. If the GFCI/RCD holds, plug in the optional light kit. If the GFCI/RCD trips, there maybe a problem with the lights. Contact Aquatic Technologies Technical Support totroubleshoot lights or pump.
	GFCI/RCD not tripped,not running.	Disconnect power. Check propeller for obstruction. These motors have internal overloads. If the propeller is jammed, the internal overload may trip. This overload may require up to 10 minutes to cool down & reset. If the motor does not restart, there may be other motor problems. Contact Aquatic Technologies Technical Support to troubleshoot the pump.
Fusion spray pattern is not reaching full size	Fusion intake clogged	Disconnect power. Check suction screen for obstruction & remove debris.
	Nozzle clogged	Disconnect power. Remove nozzle & check for obstruction & remove debris.

### Aquatic Technologies

41 Yazaki Way, Carrum Downs 3201

Ph: (03) 9071 2442

[aquaticenquiries@aquatic.net.au](mailto:aquaticenquiries@aquatic.net.au)

-OR-

Contact Your Local Distributor

2HP Fusion Series Owner's Manual

## Appendix A

### Standard Nozzle Package:

Cluster Arch .....	A1
Daffodil .....	A2
Flare .....	A3
Lily .....	A4
Super Lily .....	A5
Tornado .....	A6



A1

# Fusion Series: CLUSTER ARCH

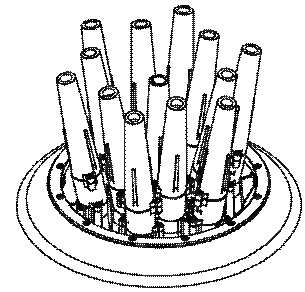

**Parts Needed:**

- Nozzle base x 1
- .5 Nozzle Tip x12
- .6 Nozzle Tip x 1
- 10° Elbow x12
- Flare Attachment x1
- Center Bolt x1
- Screw x62
- Rubber Plug x1

**1. Assemble Nozzle Groups:**

.5 Nozzle Tip

10° Elbow

2x Screw

**12 Total (Group 1)**

**2. Install Flare:**

Make sure that the Flare is installed in the down position (It should be shipped this way already)

**3. Install Nozzle Groups to Base**

Install 12x Group 1 Nozzles on holes 1-12

Use these holes so that nozzles point out away from the center

For a Twister setup install **Group 1** using the rotated (45°) holes shown here

**4. Attach Nozzle to the Unit**

Next place the Nozzle Base on the outflow and secure with the center bolt

Finally attach the plugged .6 Nozzle Tip to the center of the Nozzle Base using 2 screws

For a Twister: Follow the instructions on the "Installing Twister Module" page

Plug through bottom

A2

# Fusion Series: DAFFODIL

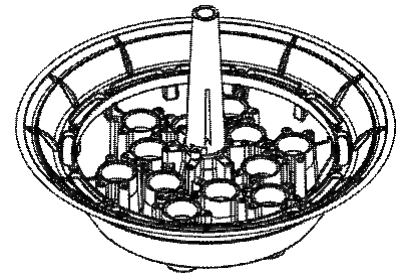

## Parts Needed:

Nozzle base  
x 1

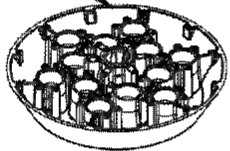

Bolt  
x1



.6 Nozzle Tip  
x 1



Flow Stopper x12

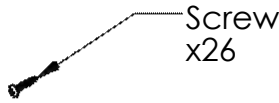

Screw  
x26

1.25 OD Washer  
x11

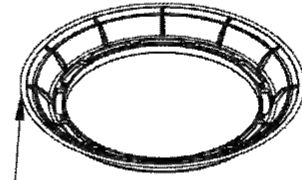

1x Flare Attachment  
(already installed)



## 1. Attach Flare to Nozzle Base:

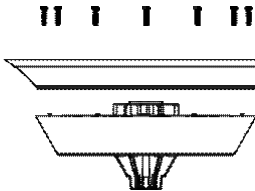

Remove the Flare (which is shipped upside down), flip it as shown and secure with 12 x screws

## 2. Install Flow Stoppers to the Nozzle Base:

Insert 12x Flow Stoppers into the bottom of the Nozzle Base, secure with 12x screws

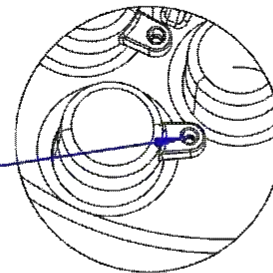

## 3. Attach the Nozzle Base

Stack 11 Washers in the cup of the Outflow

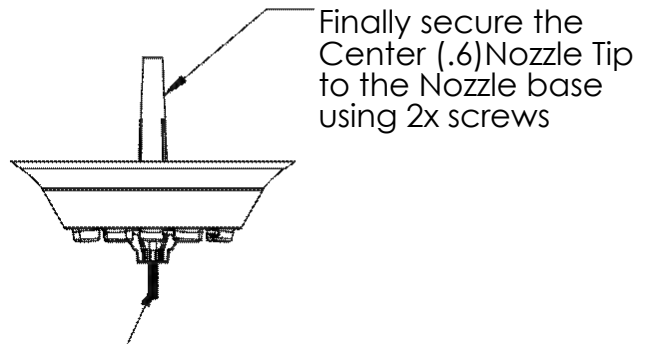
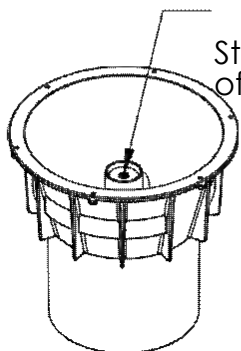

Secure the Nozzle Base to the unit using the bolt that goes through the center hole

A3

# Fusion Series: FLARE

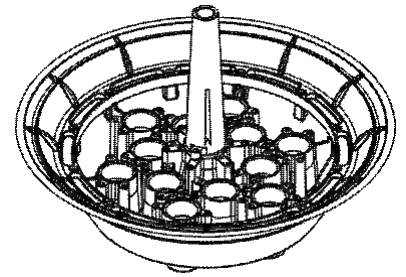

## Parts Needed:

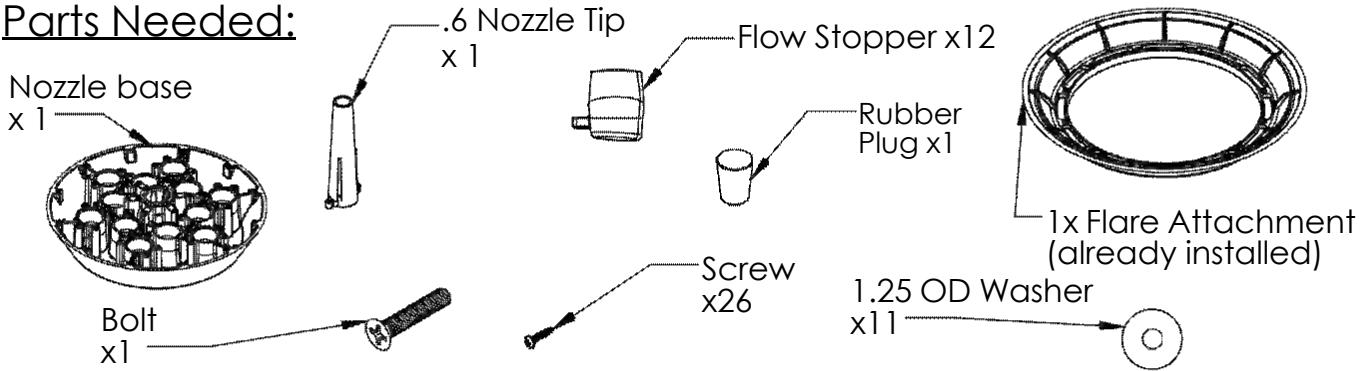

## 1. Attach Flare to Nozzle Base:

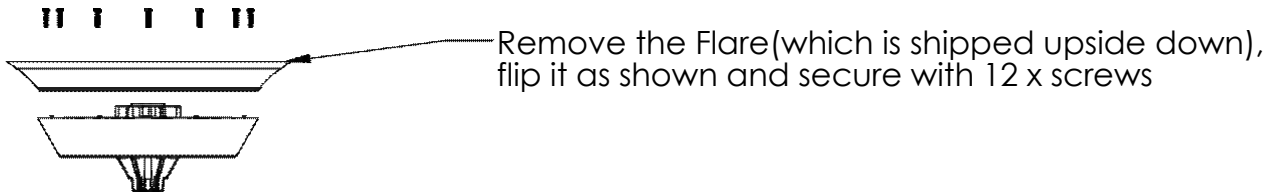

## 2. Install Flow Stoppers to the Nozzle Base:

Insert 12x Flow Stoppers into the bottom of the Nozzle Base, secure with 12x screws

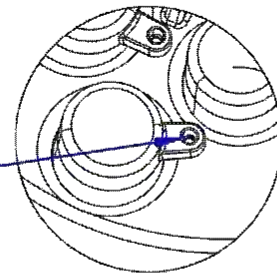

## 3. Attach the Nozzle Base

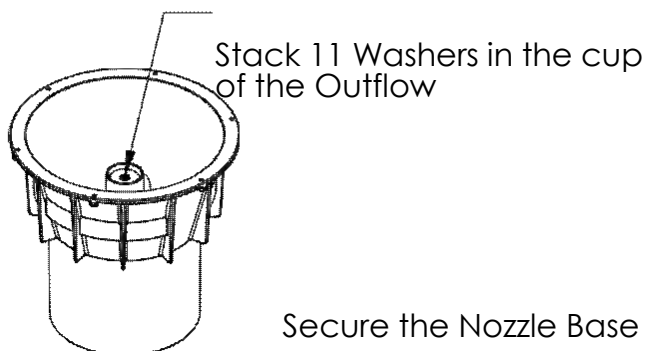

Secure the Nozzle Base to the unit using the bolt that goes through the center hole

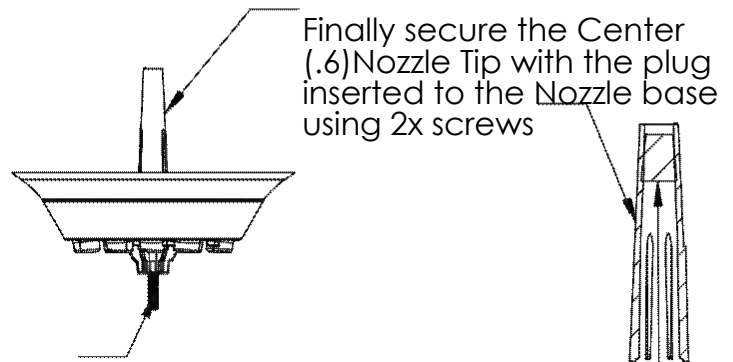

Make sure Rubber Plug is inserted into the bottom of the .6 Nozzle Tip

A4

# Fusion Series: LILY

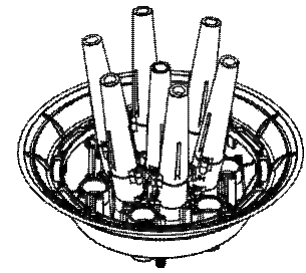

## Parts Needed:

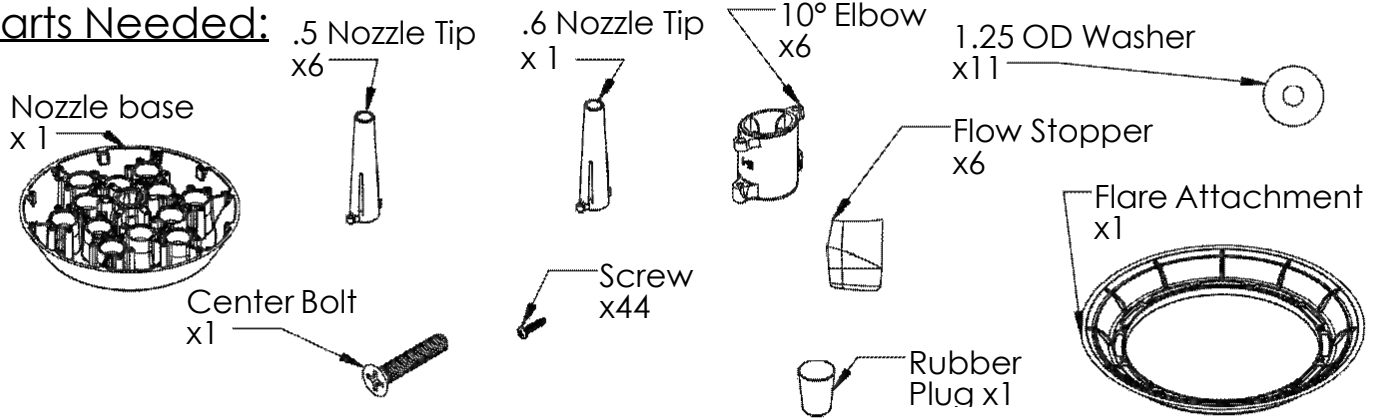

### 1. Assemble Nozzle Groups:

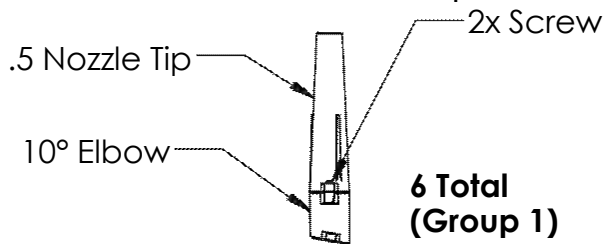

### 2. Install Flare:

(flare is shipped upside down, remove first)

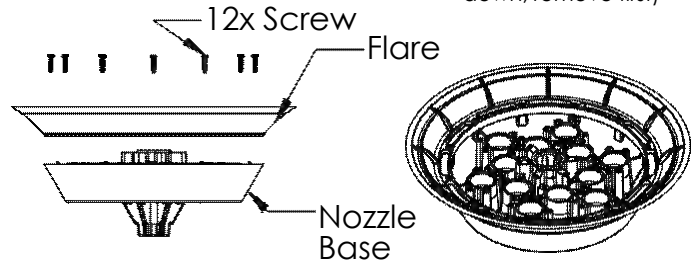

### 3. Install Nozzle Groups to Base

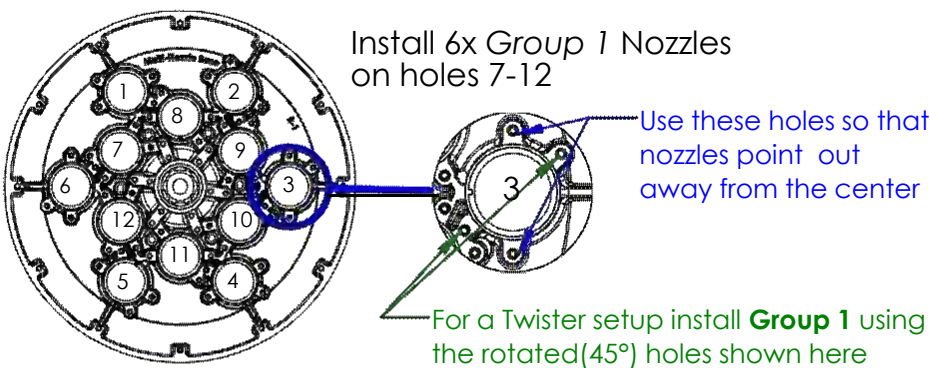

### 4. Install Flow Stopper

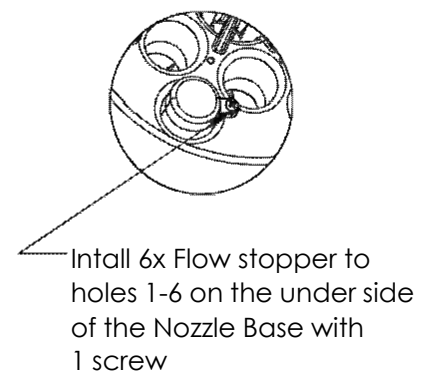

### 5. Add Washers to the Cup

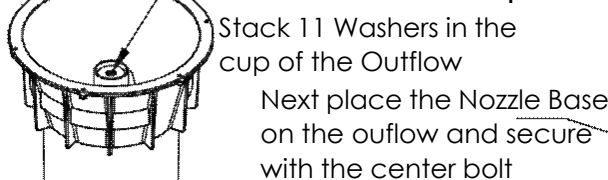

For a Twister:  
Follow the instructions on the  
"Installing Twister Module" page

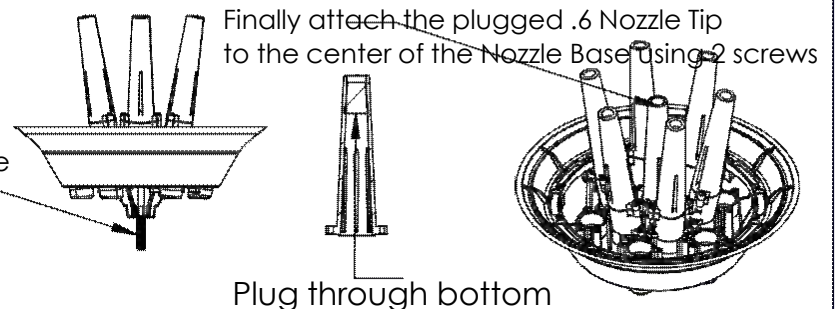



A5

# Fusion Series: SUPER LILY

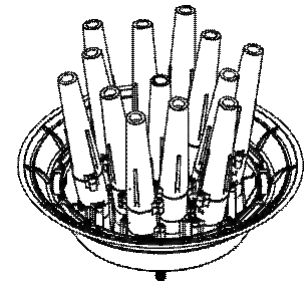

## Parts Needed:

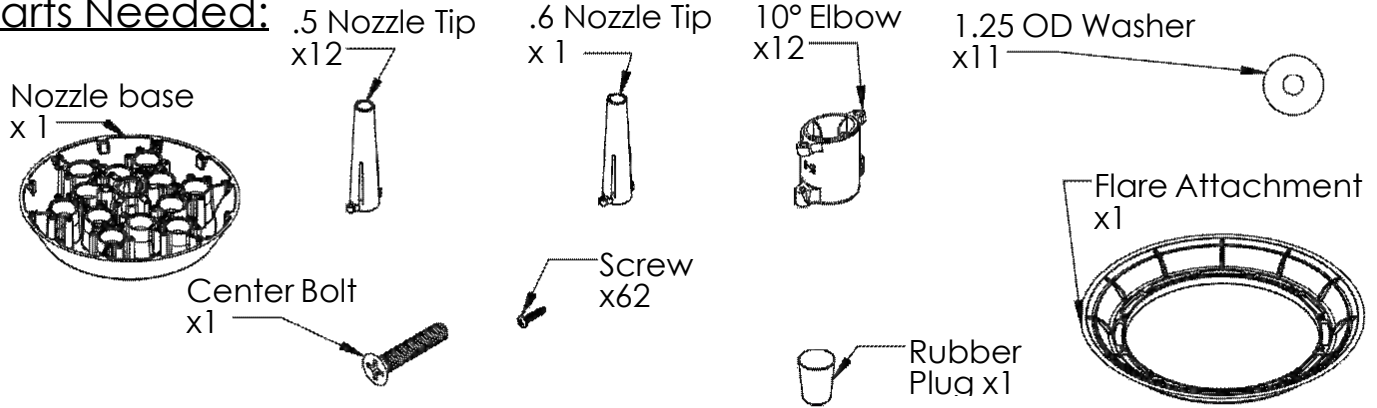

### 1. Assemble Nozzle Groups:

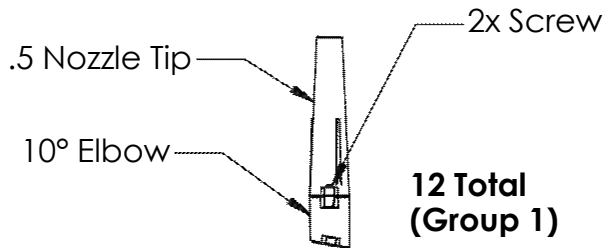

### 2. Install Flare:

(flare is shipped upside down, remove first)

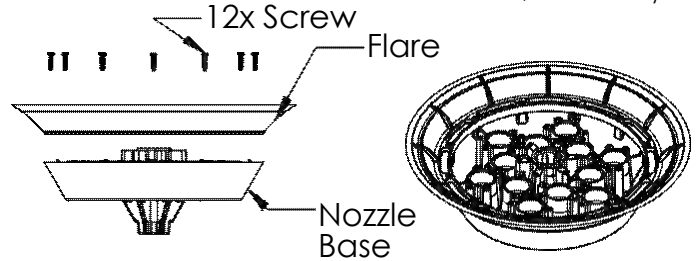

### 3. Install Nozzle Groups to Base

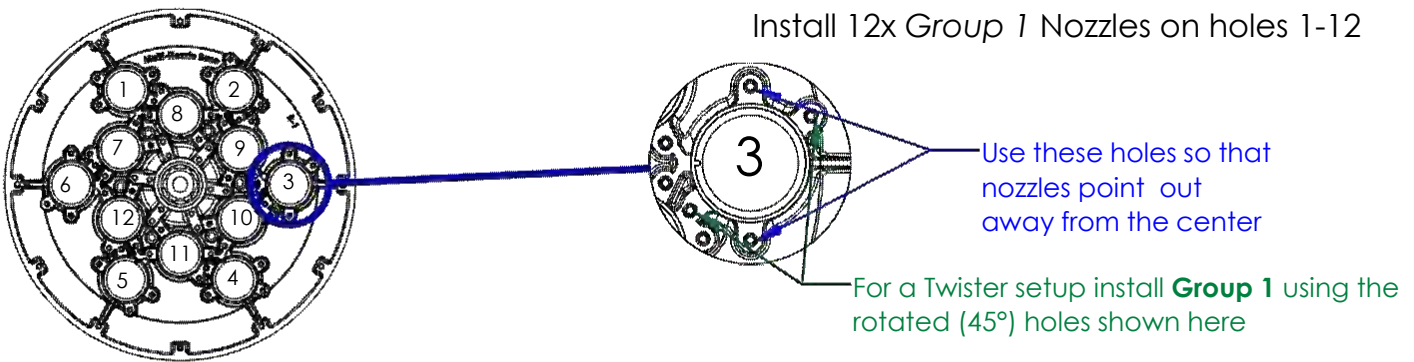

### 4. Add Washers to the Cup

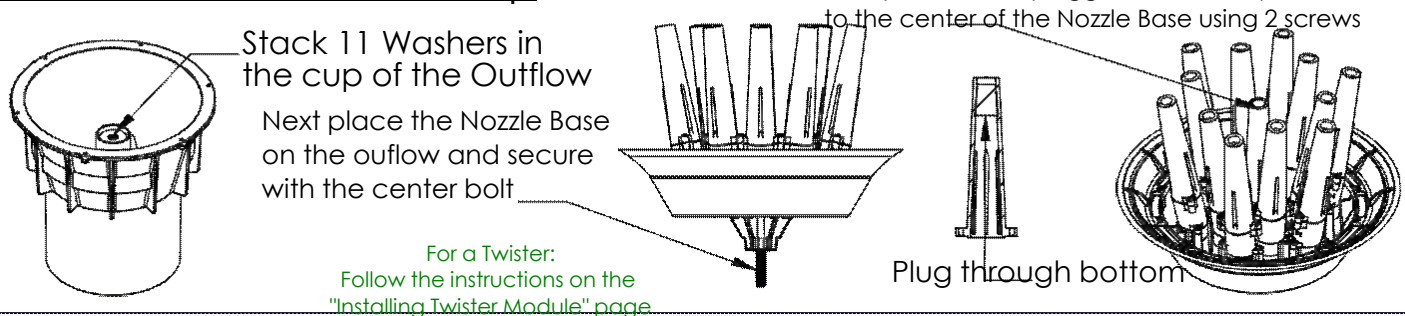

A6

# Fusion Series: TORNADO

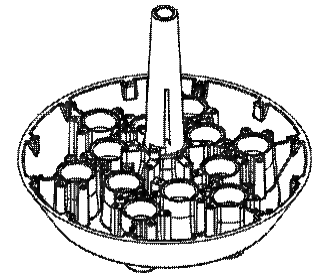

## Parts Needed:

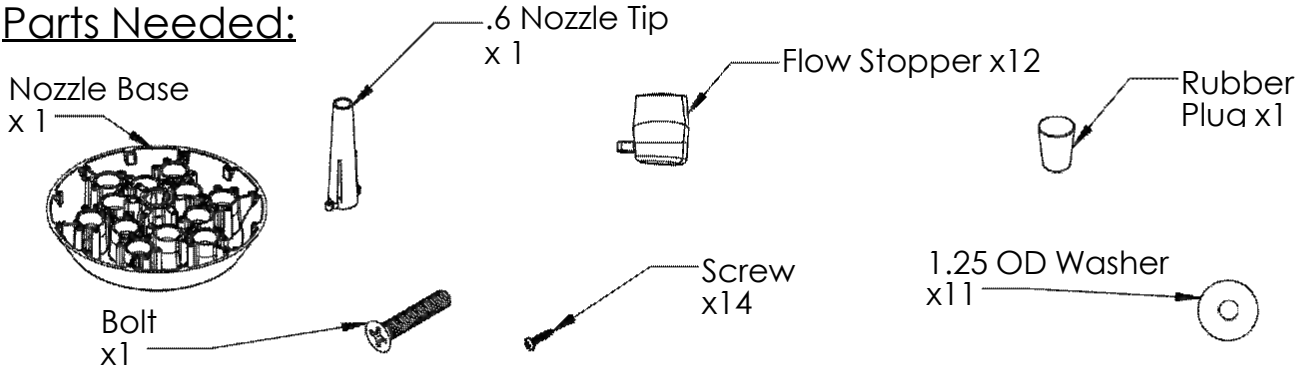

## 1. Remove Flare from Nozzle Base:

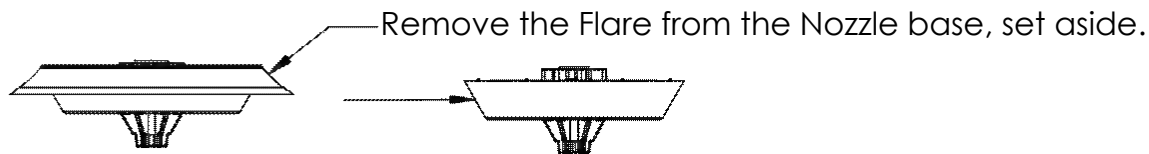

(Save for use with other patterns)

## 2. Install Flow Stoppers to the Nozzle Base:

Insert 12x Flow Stoppers into the bottom of the Nozzle Base, secure with 12x screws

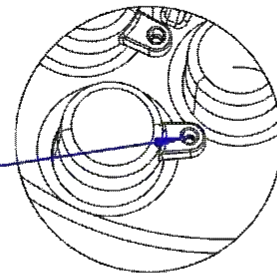

## 3. Attach the Nozzle Base

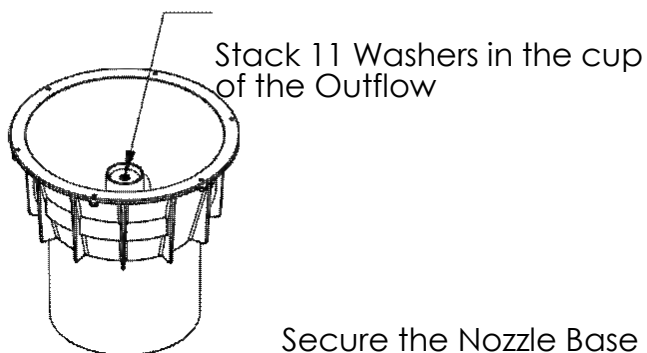

Secure the Nozzle Base to the unit using the bolt that goes through the center hole

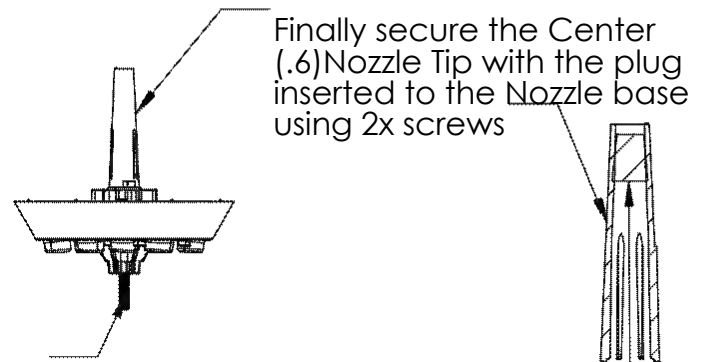

Make sure Rubber Plug is inserted into the bottom of the .6 Nozzle Tip