

Fusion Series:

Installing Twister Module

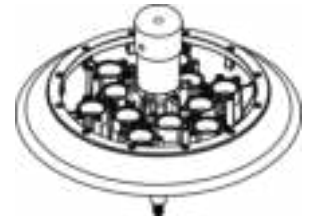

WARNING: WARRANTY VOID IF SEALS ARE REMOVED OR TWISTER MODULE IS DISASSEMBLED

1. Remove the Nozzle Base and install the Labyrinth Seal



Remove the Nozzle Base by unscrewing the center bolt



Place the Labyrinth Seal and secure using 6 screws

(Do not add the Labyrinth seal for Lily, Super Lily, and Double Arch Lily patterns)

2. Add Threaded Rod and secure

Thread the rod into the threaded insert so that the top of the rod is 7.5" above the lip of the "cup". Secure with the nut by tightening it against the face of the insert

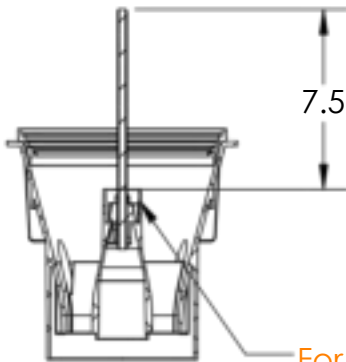

For a Lily, Super Lily, or Double Arch Lily add 4 washers to the cup before you tighten the nut down.

Tighten nut to secure

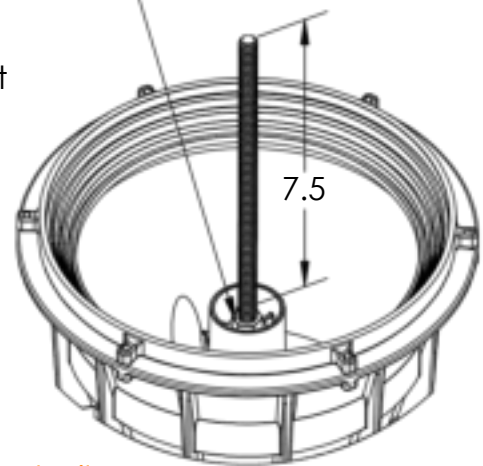

Continued on back

Installing Twister Module Continued

3. Attach the Twister Module to the Nozzle Base

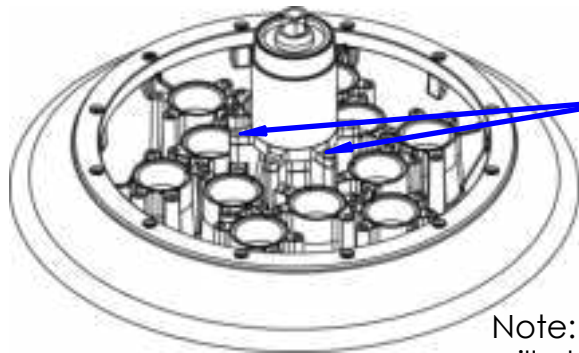

Remove the cap first from the module

Secure the Twister Module to the base using 6 of the provided screws.

Note: If converting from a Standard pattern your unit will already have nozzles installed which are not shown here

4. Spin Module and Base onto the Threaded Rod

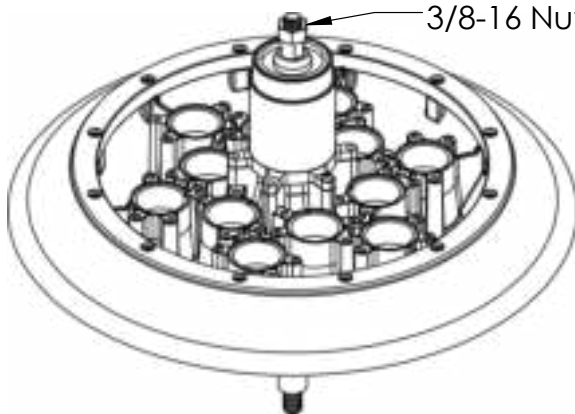

3/8-16 Nut Spin the Module and Base down the Threaded Rod until it just begins to make contact with the Labyrinth Seal

For a Lily, Super Lily, or Double Arch Lily pattern spin the base until contact is made with the nut that is in the cup below. Then spin the base 1 revolution in reverse to raise it back up, creating a gap

Screw the nut into the top of the rod and twist together with the metal shaft to tighten in place

The Nozzle Base should now spin freely, but should not raise or lower the whole assembly when spun

5. Add the Cap and finish Nozzle build

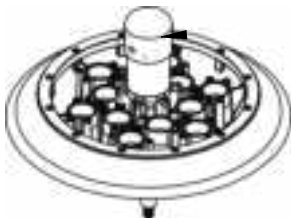

Place the cap over the Twister Module and secure through the pre-drilled hole with the screw provided.

For instructions on how to build specific Twister patterns please see the respective build page for that pattern